

Electric towing tractor 2.0 - 6.0 ton

TRACTO

S-series

4CBTY-CBTY

R-series

4CBT-CBT



Electric towing tractor 2.0 - 4.0 ton, stand-on

Truck specifications					4CBTY2	4CBTYk4
Identification	1.1	Manufacturer			Toyota	Toyota
	1.2	Model			4CBTY2	4CBTYk4
	1.3	Drive			Electric	Electric
	1.4	Operator type			Stand-on	Stand-on
	1.5	Load capacity/rated load	Q	kg	2000	4000
	1.7	Rated drawbar pull	F	N	500	1000
	1.9	Wheelbase	y	mm	1140	1140
Weight	2.1	Service weight		kg	620	730
	2.2	Axle load, with load, front/rear		kg	—	—
	2.3	Axle load, without load, front/rear		kg	220/400	270/460
Tyres	3.1	Tyre - pneumatic (P), pneumatic shaped cushion (SE), solid rubber (R)			P	P
	3.2	Tyre size, front			3.50-5-6PR	3.50-5-6PR
	3.3	Tyre size, rear			4.00-8-6PR	4.00-8-6PR
	3.5	Wheels, number front/rear (x=driven wheels)			1/2x	1/2x
	3.6	Track width, front	b ₁₀	mm	—	—
	3.7	Track width, rear	b ₁₁	mm	685	685
	Dimensions	4.8	Seat height/stand height	h ₇	mm	200
4.12		Coupling height	h ₁₀	mm	305	305
4.17		Overhang	l ₅	mm	215	215
4.19		Overall length	l ₁	mm	1645	1645
4.21		Overall width	b ₁	mm	800	800
4.32		Ground clearance, centre of wheelbase	m ₂	mm	80	80
4.35		Turning radius	W _a	mm	1600	1600
Performance data	5.1	Travel speed, with/without load		km/h	9 ¹ /13	8 ² /13
	5.6	Max. drawbar pull, with/without load		N	2000	4000
	5.8	Max. gradeability, with/without load		%	5/14	7/14
	5.10	Service brake			Hydraulic	Hydraulic
Electric motor	6.1	Drive motor rating S2 60 min		kW	2,3	2,3
	6.4	Battery voltage, nominal capacity K _s		V/Ah	48/129	48/220
	6.5	Battery weight		kg	260	370
Other	8.1	Type of drive control			Transistor inverter	Transistor inverter
	8.4	Sound level at driver's ear according to EN 12053		dB(A)		

¹) with 2 ton load

²) with 4 ton load

Performance data and dimensions are nominal and subject to tolerances.
Specifications are subject to change without notice.
Please obtain the latest specifications before contracting products.

Towed weight

TRACTO

Model		4CBTY2	4CBTYk4	4CBTY2	4CBTYk4
Surface condition (Dry even concrete)		3-minute rating		60-minute rating	
Start, level road	ton	2,0	4,0	2,0	4,0
Start, 1 degree	ton	1,6	3,7	0,9	2,0
Start, 2 degrees	ton	1,2	3,0	0,4	1,2
Start, 3 degrees	ton	1,0	2,5	0,1	0,7
Start, 4 degrees	ton	0,8	2,1	—	0,4

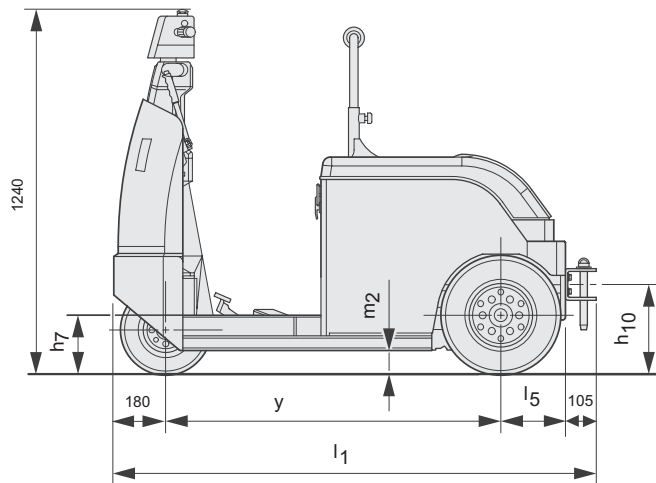
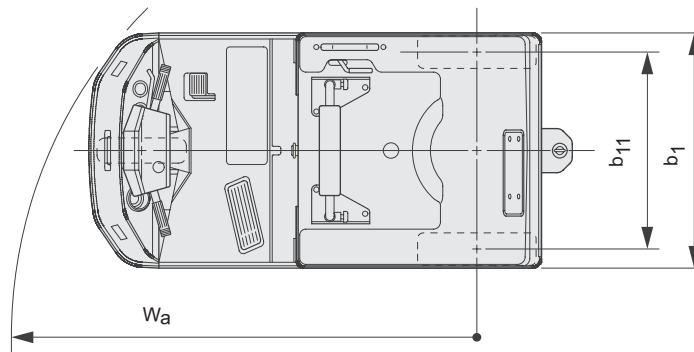

Electric towing tractor 2.0 - 4.0 ton, sit-on

Truck specifications					4CBT2	4CBT3	4CBT4
Identification	1.1	Manufacturer			Toyota	Toyota	Toyota
	1.2	Model			4CBT2	4CBT3	4CBT4
	1.3	Drive			Electric	Electric	Electric
	1.4	Operator type			Sit-on	Sit-on	Sit-on
	1.5	Load capacity/rated load	Q	kg	2000	3000	4000
	1.7	Rated drawbar pull	F	N	500	750	1000
	1.9	Wheelbase	y	mm	1140	1140	1140
Weight	2.1	Service weight		kg	620	620	730
	2.2	Axle load, with load, front/rear		kg	—	—	—
	2.3	Axle load, without load, front/rear		kg	220/400	220/400	270/460
Tyres	3.1	Tyre - pneumatic (P), pneumatic shaped cushion (SE), solid rubber (R)			P	P	P
	3.2	Tyre size, front			3.50-5-6PR	3.50-5-6PR	3.50-5-6PR
	3.3	Tyre size, rear			4.00-8-6PR	4.00-8-6PR	4.00-8-6PR
	3.5	Wheels, number front/rear (x=driven wheels)			1/2x	1/2x	1/2x
	3.6	Track width, front	b ₁₀	mm	—	—	—
	3.7	Track width, rear	b ₁₁	mm	685	685	685
	Dimensions	4.8	Seat height/stand height	h ₇	mm	860	860
4.12		Coupling height	h ₁₀	mm	305	305	305
4.17		Overhang	l ₅	mm	215	215	215
4.19		Overall length	l ₁	mm	1645	1645	1645
4.21		Overall width	b ₁	mm	800	800	800
4.32		Ground clearance, centre of wheelbase	m ₂	mm	80	80	80
4.35		Turning radius	W _a	mm	1600	1600	1600
Performance data	5.1	Travel speed, with/without load		km/h	9 ¹ /13	9 ² /13	8 ³ /13
	5.6	Max. drawbar pull, with/without load		N	2000	3000	4000
	5.8	Max. gradeability, with/without load		%	5/14	7/14	8/14
	5.10	Service brake			Hydraulic	Hydraulic	Hydraulic
Electric motor	6.1	Drive motor rating S2 60 min		kW	2,3	2,3	2,3
	6.4	Battery voltage, nominal capacity K _s		V/Ah	48/129	48/129	48/220
	6.5	Battery weight		kg	260	260	370
Other	8.1	Type of drive control			Transistor inverter	Transistor inverter	Transistor inverter
	8.4	Sound level at driver's ear according to EN 12053		dB(A)			

¹⁾ with 2 ton load

²⁾ with 3 ton load

³⁾ with 4 ton load

Performance data and dimensions are nominal and subject to tolerances.
Specifications are subject to change without notice.
Please obtain the latest specifications before contracting products.

Towed weight

TRACTO

Model		4CBT2	4CBT3	4CBTk4	4CBT2	4CBT3	4CBTk4
Surface condition (Dry even concrete)		3-minute rating			60-minute rating		
Start, level road	ton	2,0	3,0	4,0	2,0	3,0	4,0
Start, 1 degree	ton	1,6	2,7	3,7	0,9	1,4	2,0
Start, 2 degrees	ton	1,2	2,1	3,0	0,4	0,8	1,2
Start, 3 degrees	ton	1,0	1,7	2,5	0,1	0,4	0,7
Start, 4 degrees	ton	0,8	1,4	2,1	—	0,2	0,4

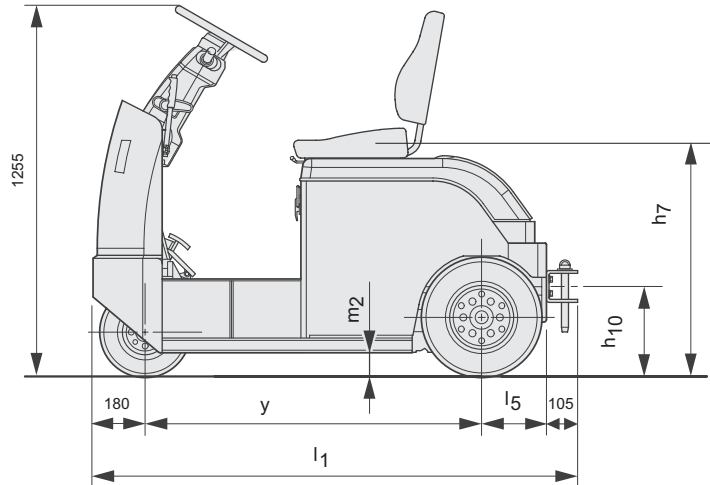
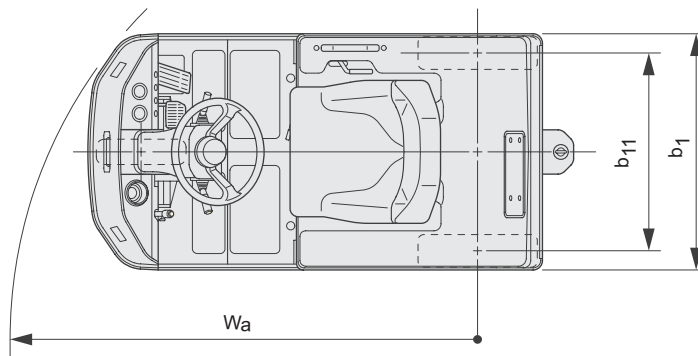

Electric towing tractor 2.0 - 4.0 ton, stand-on and sit-on

Truck specifications					CBTY4	CBT4	CBT6
Identification	1.1	Manufacturer			Toyota	Toyota	Toyota
	1.2	Model			CBTY4	CBT4	CBT6
	1.3	Drive			Electric	Electric	Electric
	1.4	Operator type			Stand-on	Sit-on	Sit-on
	1.5	Load capacity/rated load	Q	kg	4000	4000	6000
	1.7	Rated drawbar pull	F	N	980	980	1470
	1.9	Wheelbase	y	mm	1140	1360	1360
Weight	2.1	Service weight		kg	915	970	1035
	2.2	Axle load, with load, front/rear		kg	—	—	—
	2.3	Axle load, without load, front/rear		kg	290/685	330/650	360/695
Tyres	3.1	Tyre - pneumatic (P), pneumatic shaped cushion (SE), solid rubber (R)			P	P	P
	3.2	Tyre size, front			3.50-5-6PR	3.50-5-6PR	3.50-5-6PR
	3.3	Tyre size, rear			4.00-8-6PR	4.00-8-6PR	4.00-8-6PR
	3.5	Wheels, number front/rear (x=driven wheels)			2/2x	2/2x	2/2x
	3.6	Track width, front	b ₁₀	mm	260	260	260
	3.7	Track width, rear	b ₁₁	mm	805	805	805
	Dimensions	4.8	Seat height/stand height	h ₇	mm	200	860
4.12		Coupling height	h ₁₀	mm	305	305	305
4.17		Overhang	l ₅	mm	240	360	360
4.19		Overall length	l ₁	mm	1755	2020	2020
4.21		Overall width	b ₁	mm	965	965	965
4.32		Ground clearance, centre of wheelbase	m ₂	mm	75	80	80
4.35		Turning radius	W _a	mm	1600	1775	1775
Performance data	5.1	Travel speed, with/without load		km/h	9 ¹⁾ /13,5	9 ¹⁾ /13,5	13 ²⁾ /18
	5.6	Max. drawbar pull, with/without load		N	3920	3920	4410
	5.8	Max. gradeability, with/without load		%	6 ¹⁾ /36	6 ¹⁾ /36	3 ²⁾ /32
	5.10	Service brake			Hydraulic	Hydraulic	Hydraulic
Electric motor	6.1	Drive motor rating S2 60 min		kW	2,6	2,6	4,9
	6.4	Battery voltage, nominal capacity K _s		V/Ah	48/160	48/240	48/240
	6.5	Battery weight		kg	290	450	450
Other	8.1	Type of drive control			Transistor chopper	Transistor chopper	Transistor chopper
	8.4	Sound level at driver's ear according to EN 12053		dB(A)	71	71	69

¹⁾ with 2 ton load

²⁾ with 3 ton load

Performance data and dimensions are nominal and subject to tolerances.
Specifications are subject to change without notice.
Please obtain the latest specifications before contracting products.

Towed weight

TRACTO

Model		CBTY4	CBT4	CBT6	CBTY4	CBT4	CBT6
Surface condition (Dry even concrete)		3-minute rating			60-minute rating		
Start, level road	ton	4,0 (7)	4,0 (7)	6,0 (7)	4,0 (7)	4,0 (7)	6,0 (7)
Start, 1 degree	ton	3,4 (4)	3,4 (4)	3,8 (4)	1,9 (7)	1,9 (7)	3,0 (7)
Start, 2 degrees	ton	2,7 (4)	2,7 (4)	3,0 (4)	1,0 (7)	1,0 (7)	1,8 (7)
Start, 3 degrees	ton	2,2 (4)	2,2 (4)	2,4 (4)	0,5 (7)	0,5 (7)	1,1 (7)
Start, 4 degrees	ton	1,7 (4)	1,7 (4)	2,0 (4)	0,2 (7)	0,2 (7)	0,6 (7)

() indicates travel speed in km/h

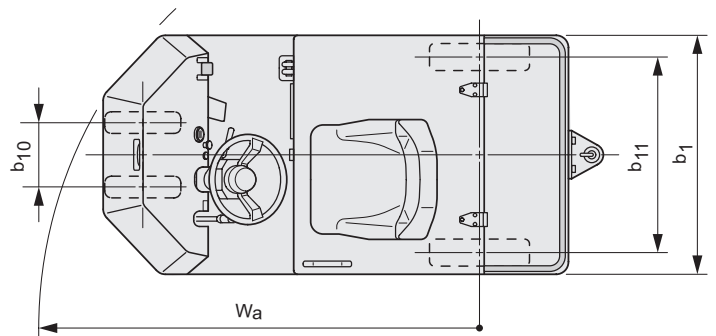
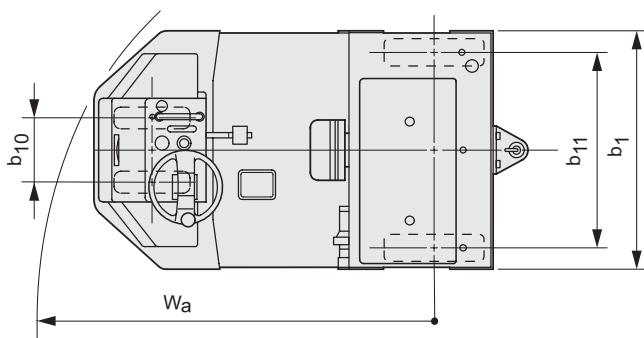
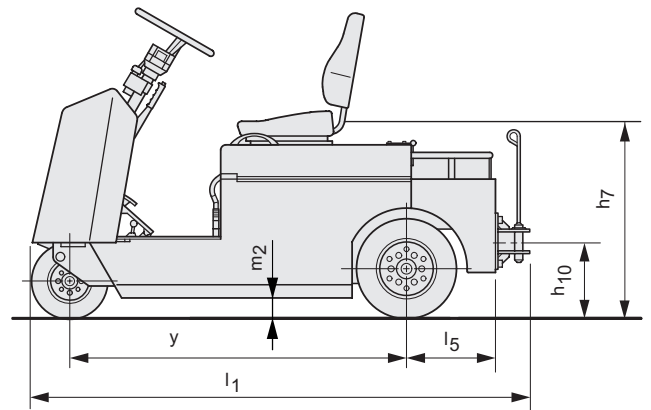
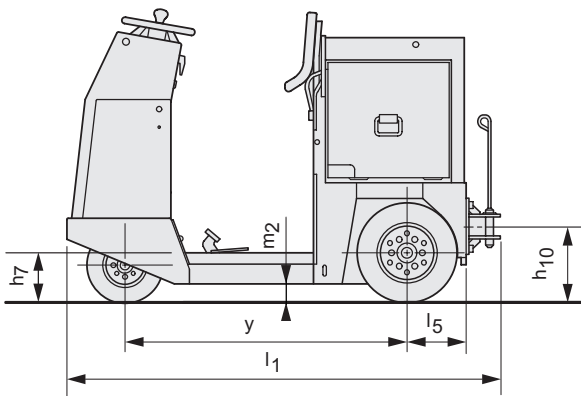

Standard equipment:

- Toyota OPS (Operator Presence Sensing)
- AC power system
- Pneumatic tyres
- Rear drawbar
- Headlight
- Battery discharge indicator
- Hour meter
- Battery rollerbed (only standard on CBTY4)
- Document box



TP-Technical Publications, Sweden — 745542-040, version 2, 1202

TOYOTA

MATERIAL HANDLING