

Pedestrian lowlifter truck 1.6 ton



BT levio

W-series

LWI160

LI-ION



Pedestrian lowlifter truck

Specification for lowlifter trucks					LWI160
Identification	1.1	Manufacturer			Toyota
	1.2	Model			LWI160
	1.3	Drive			Electric
	1.4	Operator type			Pedestrian
	1.5	Load capacity/rated load	Q	kg	1600
	1.6	Load center	c	mm	600
	1.8	Load distance (forks raised/lowered)	x	mm	908/970
	1.9	Wheelbase (forks raised/lowered)	y	mm	1178/1240
	Weight	2.1	Service weight including battery		kg
2.2		Axle load, with load, drive/castor/fork wheel		kg	610/61/1203
2.3		Axle load, without load, drive/castor/fork wheel		kg	172/48/54
Wheels	3.1	Drive/castor/fork wheel			Prime/Polyurethane/Prime
	3.2	Wheel size, front		mm	Ø230x70
	3.3	Wheel size, rear		mm	Ø85x97
	3.4	Additional wheels (dimensions)		mm	Ø100x40
	3.5	Wheels, number front/rear (x = driven wheels)			1x + 2 / 2 or 4
	3.6	Track width, front	b ₁₀	mm	502
	3.7	Track width, rear	b ₁₁	mm	370
Dimensions	4.4	Lift	h ₃	mm	125
		Lift height	h ₂₃	mm	215
	4.9	Height of tiller in drive position, min./max.	h ₁₄	mm	865/1235
	4.15	Height, fork lowered	h ₁₃	mm	85
	4.19	Overall length	l ₁	mm	1569
	4.20	Length to face of forks	l ₂	mm	419
	4.21	Overall width	b ₁	mm	726
	4.22	Fork dimensions	s/e/l	mm	50/180/1150
	4.25	Width over forks	b ₅	mm	550
	4.32	Ground clearance, center of wheelbase	m ₂	mm	33
	4.34.1	Aisle width for pallets 1000x1200 crossways	A _{st}	mm	2145
	4.34.2	Aisle width for pallets 800x1200 lengthways	A _{st}	mm	2033
	4.35	Turning radius (forks raised/lowered)	W _a	mm	1338/1400
Performance data	5.1	Travel speed, with/without load		km/h	6/6
	5.2	Lift speed, with/without load		m/s	0,047/0,056
	5.3	Lowering speed, with/without load		m/s	0,012/0,04
	5.8	Max. gradeability, with/without load		%	10/18
	5.9	Acceleration time without load (10 m)		s	6,3
	5.10	Service brake			Electromagnetic
Electric motor	6.1	Drive motor rating 6 km/h version		kW	1,0
	6.2	Lift motor rating at S3 10%		kW	1,0
	6.4	Battery voltage/nominal capacity K _s		V/Ah	24/50, 105, 150
	6.5	Battery weight		kg	6.4, 16.0, 21.5
	6.6	Energy consumption acc. to VDI cycle		kWh/h	
	Others	8.1	Type of drive control		
8.4		Sound level at the driver's ear according to EN 12 053		dB (A)	59

Data is based on standard configurations.

Truck performance and dimensions are nominal and subject to tolerances.

Toyota Material Handling Manufacturing Sweden AB products and specifications are subject to change without notice.

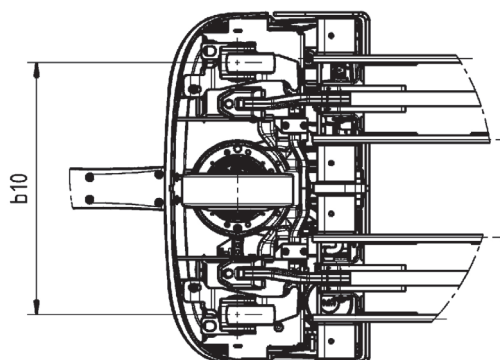
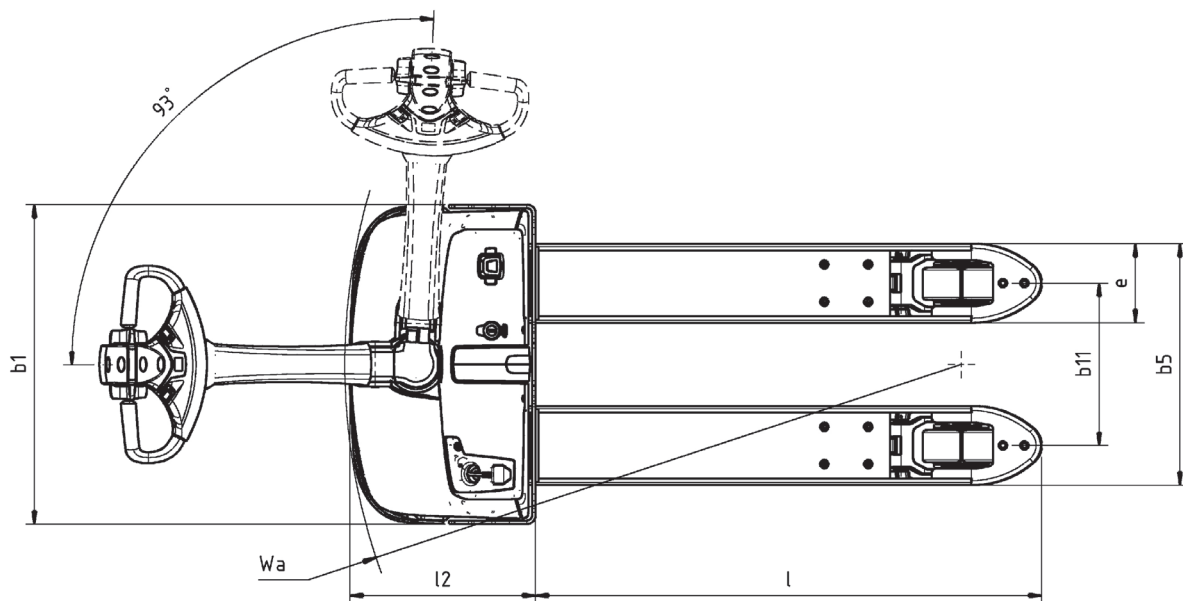
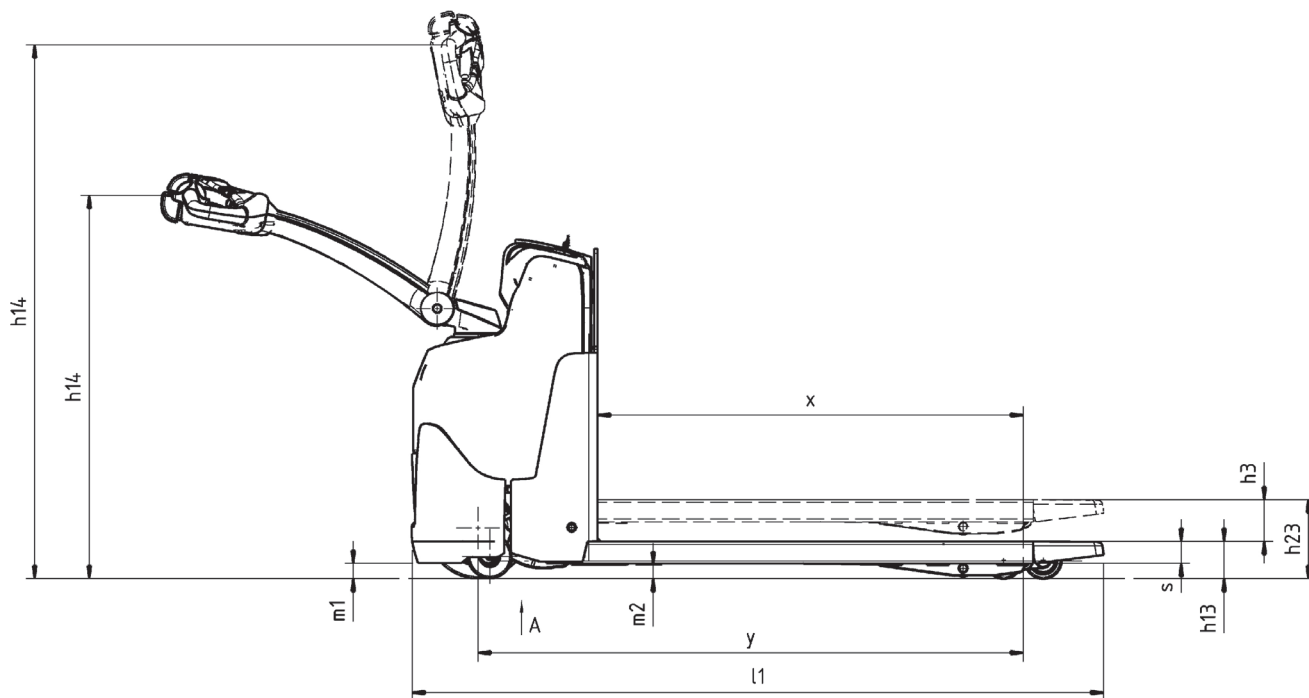

Truck features:

- BT Castorlink System
- Click-2-creep
- Fingertip controls
- Temporary speed reduction - turtle button (option)
- Optimised Corner Control
- Electronic braking system
- Electronic speed control
- Operator safety
- Automatic switch-off
- Programmable performance
- Easy access for maintenance
- Smart truck and Toyota I_Site: truck fleet management system
- Electrical outlet
- Built in charger (option)
- Oil for low temperatures (option)
- Food grade oil (option)

